

9854/56 | Urmet notice



Buzzer électronique universel 12

Vcc ou ca

Réf 9854/56

20.58€^{TTC*}

Voir le produit : <https://www.domomat.com/31840-buzzer-electronique-universel-12-vcc-ou-ca-urmet-9854-56.html>

*Le produit Buzzer électronique universel 12 Vcc ou ca
est en vente chez Domomat !*

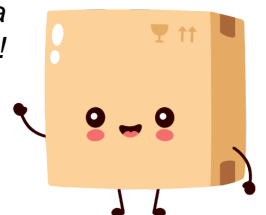

BUZZER UNIVERSALE
UNIVERSAL BUZZER
RONFLEUR UNIVERSEL
ZUMBADOR UNIVERSAL
UNIVERSAL-SUMMER

Sch./Ref. 9854/56

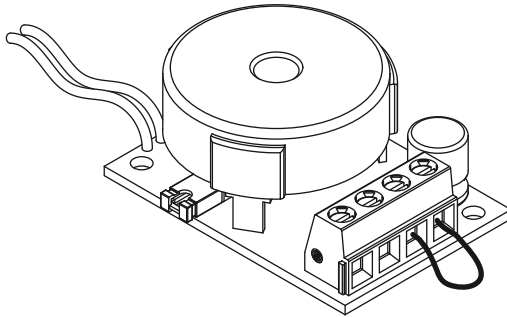

ITALIANO

Il buzzer universale può essere utilizzato sia per rendere compatibile il citofono con chiamata elettronica in impianti tradizionali sia per gestire la chiamata intercomunicante o la chiamata al piano.

INSTALLAZIONE

Fissare il dispositivo all'interno dei citofoni o videocitofoni come mostrato di seguito utilizzando le viti fornite a corredo:

**Mod.1130
Mod.1131**

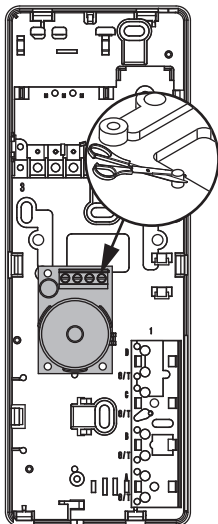

Scaitel

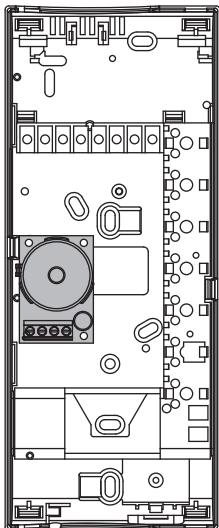

Atlantico

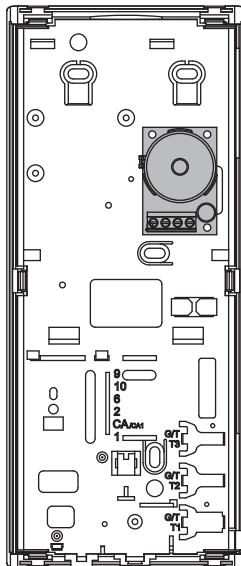

Utopia

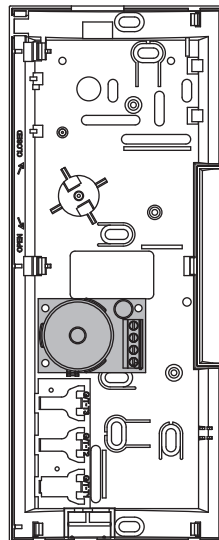

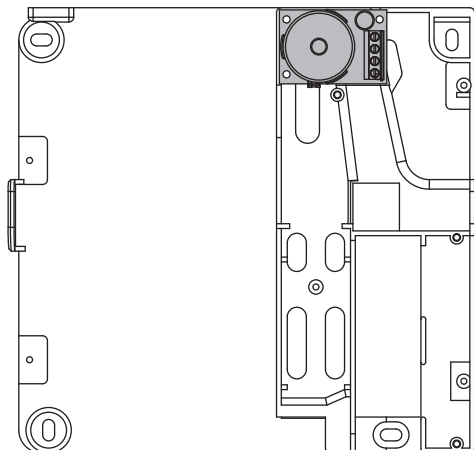

Winflat Winspot Atlantico

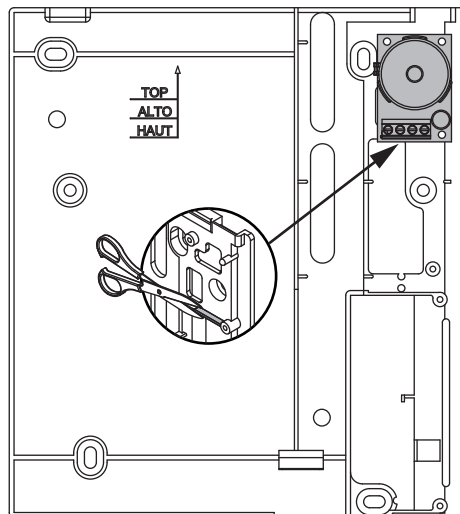

Artico Arco

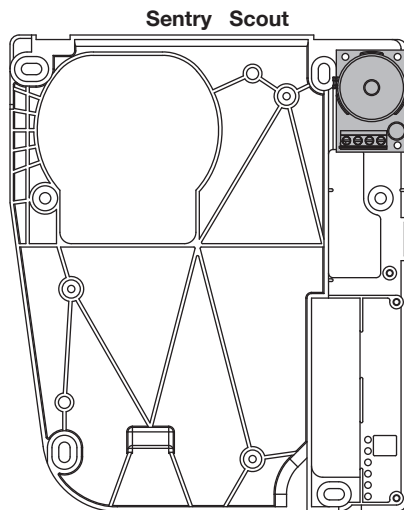
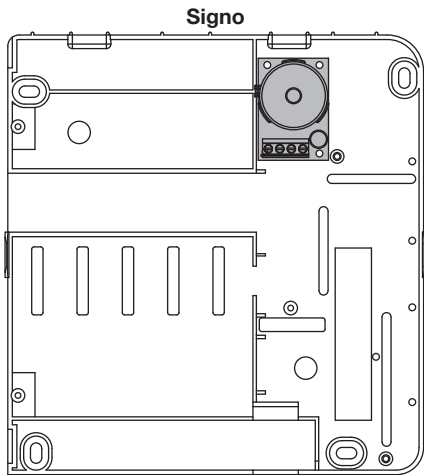



 Se il buzzer è utilizzato con i dispositivi a relè Sch. 788/51 e Sch. 788/58 occorre inserire la resistenza da 47 Ohm spostando il jumper.

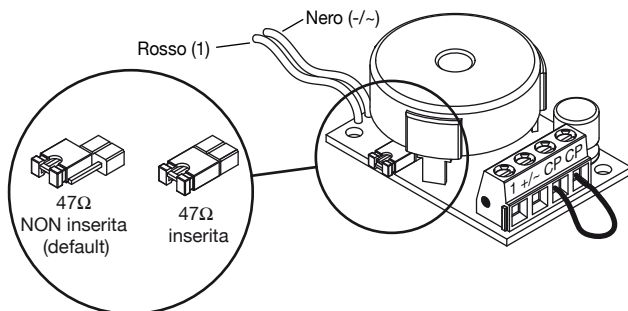

SOSTITUZIONE DI MODELLI PRECEDENTI

Descrizione	Sch. 9854/56	Sch. 1131/7	Sch. 9854/52	Sch. 9854/53
Alimentazione	+/~	RZ	+/~	CH
	-/~ (filo nero)	filo nero	-/~	
Chiamata al piano	CP			CP+
	CP			CP-
Resistenza riduzione fonia	1	1		
	1 (filo rosso)	filo rosso		

ENGLISH

The universal buzzer can be used to make the door phone compatible with the electronic call in traditional systems and to manage the intercom call or the floor call.

INSTALLATION

Fix the device in door phones or video door phones, as shown below, using the provided screws:

Mod.1130
Mod.1131

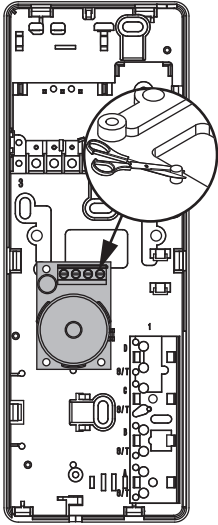

Scaitel

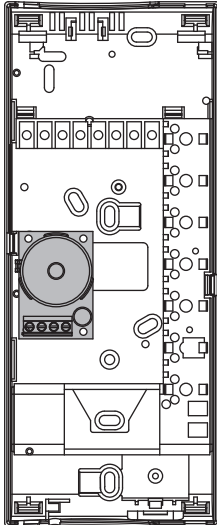

Atlantico

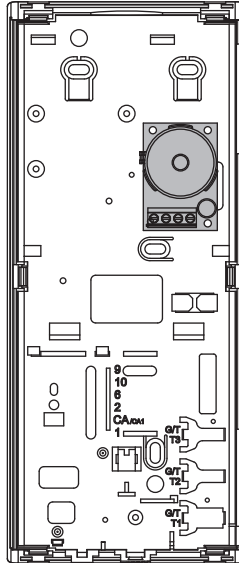

Utopia

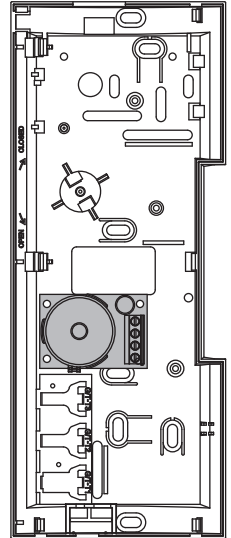

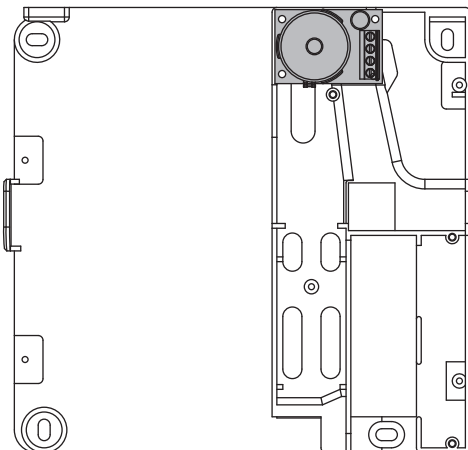

Winflat Winspot Atlantico

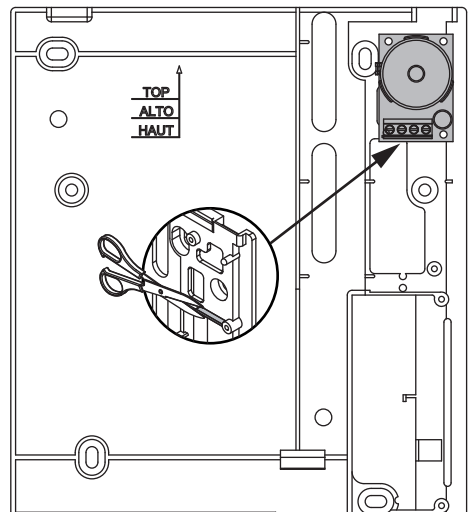

Artico Arco

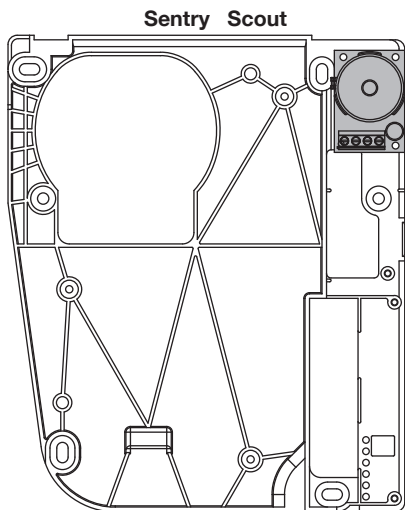
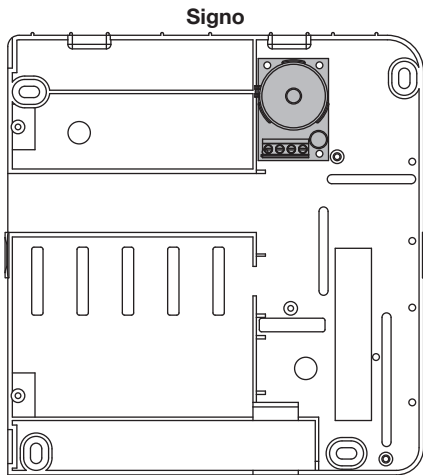



 If the buzzer is used with relay devices Ref. 788/51 and Ref. 788/58, insert the 47 Ohm resistor, moving the jumper.

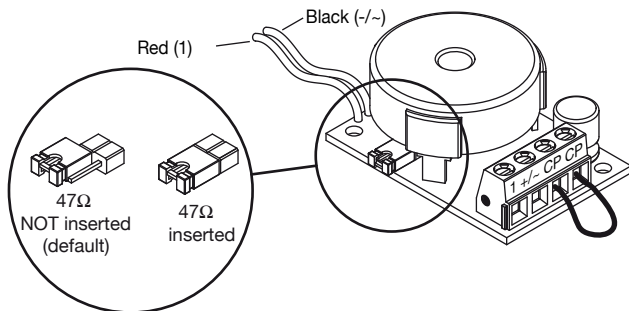

REPLACEMENT OF OLD MODELS

Description	Ref. 9854/56	Ref. 1131/7	Ref. 9854/52	Ref. 9854/53
Power supply	+/~	RZ	+/~	CH
	-/~ (black wire)	black wire	-/~	
Floor call	CP			CP+
	CP			CP-
Resistor for audio attenuation	1	1		
	1 (red wire)	red wire		

FRANÇAIS

Le ronfleur universel peut être utilisé aussi bien pour rendre compatible l'interphone avec l'appel électronique dans des systèmes traditionnels que pour gérer l'appel intercom ou l'appel à l'étage.

INSTALLATION

Fixer le dispositif à l'intérieur des interphones ou des vidéophones, comme montré ci-dessous, en utilisant les vis livrées:

**Mod.1130
Mod.1131**

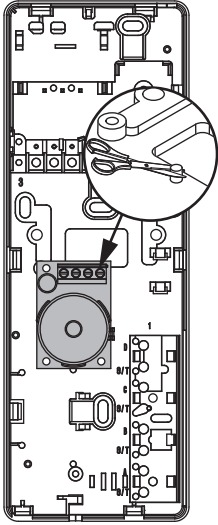

Scaitel

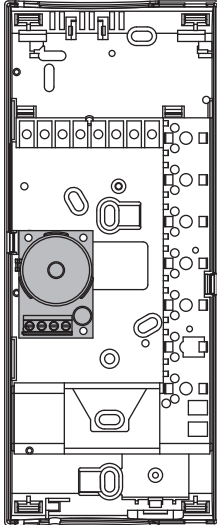

Atlantico

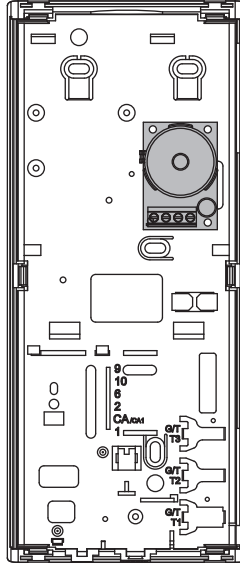

Utopia

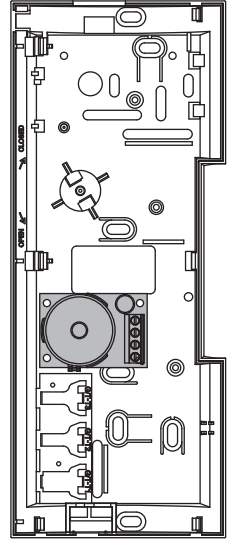

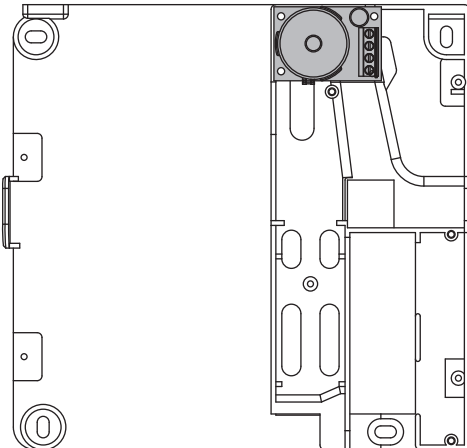

Winflat Winspot Atlantico

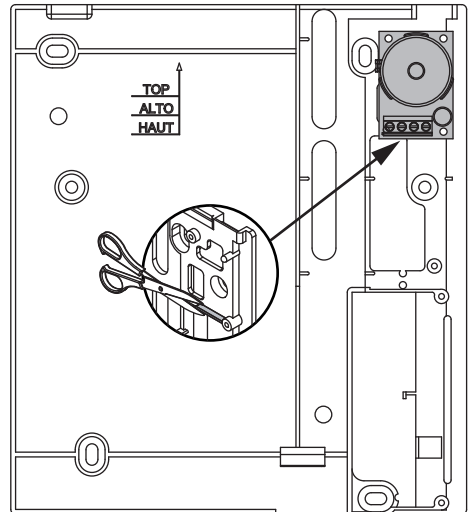

Artico Arco

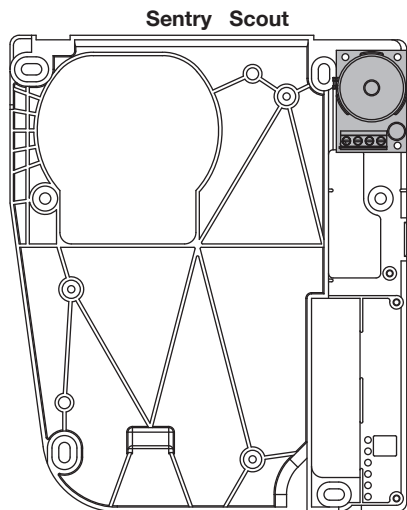
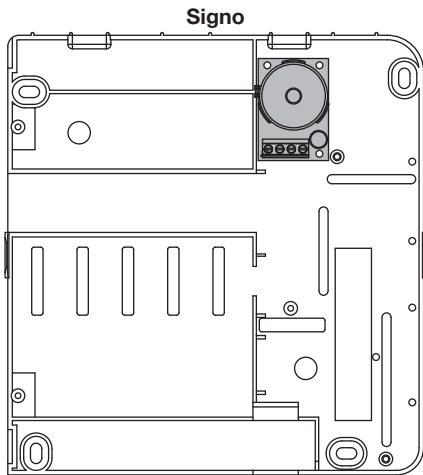



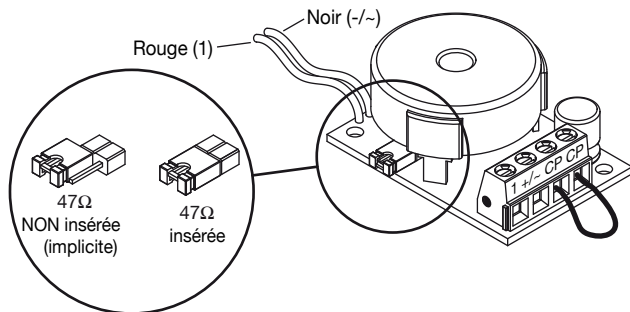

 Si le ronfleur est utilisé avec les dispositifs à relais Réf. 788/51 et Réf. 788/58, il faut insérer la résistance de 47 Ohm en déplaçant le pontet.

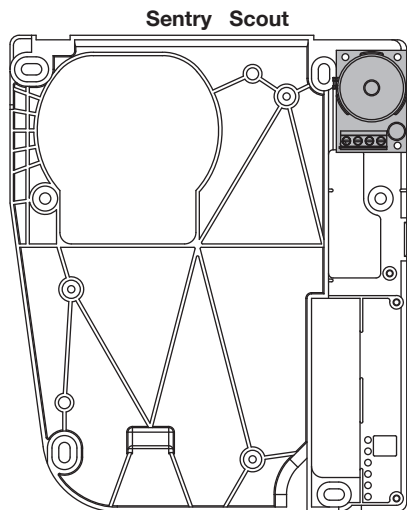
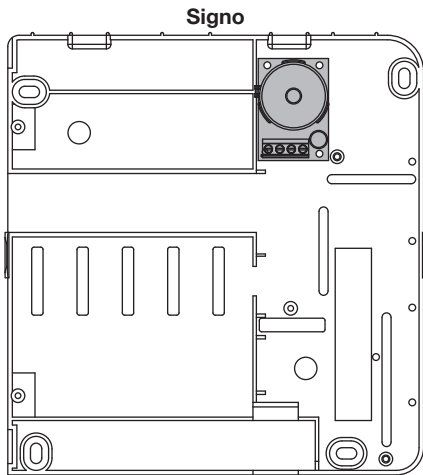

REPLACEMENT DES VIEUX MODÈLES

Description	Réf. 9854/56	Réf. 1131/7	Réf. 9854/52	Réf. 9854/53
Alimentation	+/~	RZ	+/~	CH
	-/~ (fil noir)	fil noir	-/~	
Appel à l'étage	CP			CP+
	CP			CP-
Résistance pour atténuation phonie	1	1		
	1 (fil rouge)	fil rouge		



 Si el zumbador viene utilizado con dispositivos con relé Ref. 788/51 y Ref. 788/58 es necesario conectar la resistencia de 47 Ohm moviendo el jumper.

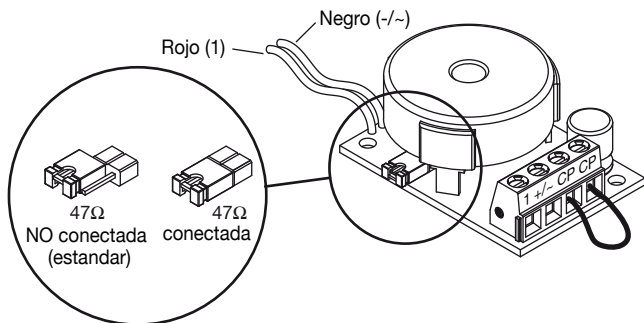

SUSTITUCIÓN DE MODELOS ANTERIORES

Descripción	Ref. 9854/56	Ref. 1131/7	Ref. 9854/52	Ref. 9854/53
Alimentación	+/~	RZ	+/~	CH
	-/~ (hilo negro)	hilo negro	-/~	
Llamada al piso	CP			CP+
	CP			CP-
Resistencia diminución fonía	1	1		
	1 (hilo rojo)	hilo rojo		

DEUTSCH

Der Universal-Summer ermöglicht Kompatibilität des Hausteles mit elektronischem Rufton zu den traditionellen Anlagen und kann auch den interkommunizierenden Ruf oder die Etagenruf verwalten.

INSTALLATION

Das Gerät in den Hausteles oder Videohausteles mit den mitgelieferten Schrauben wie gezeigt befestigen:

**Mod.1130
Mod.1131**

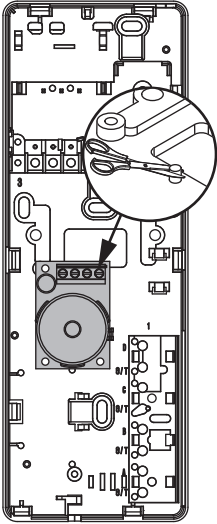

Scaitel

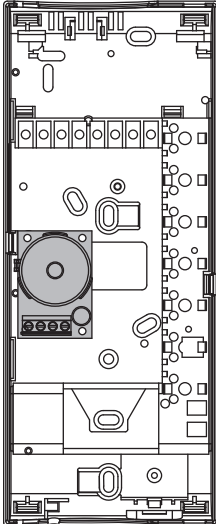

Atlantico

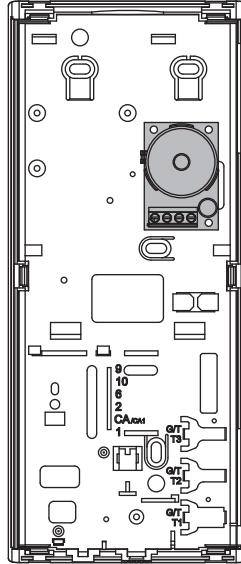

Utopia

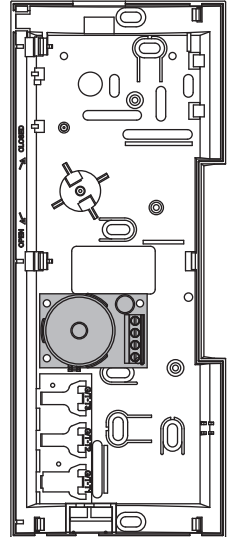

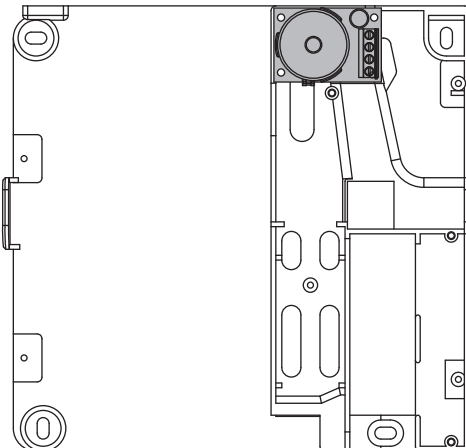

Winflat Winspot Atlantico

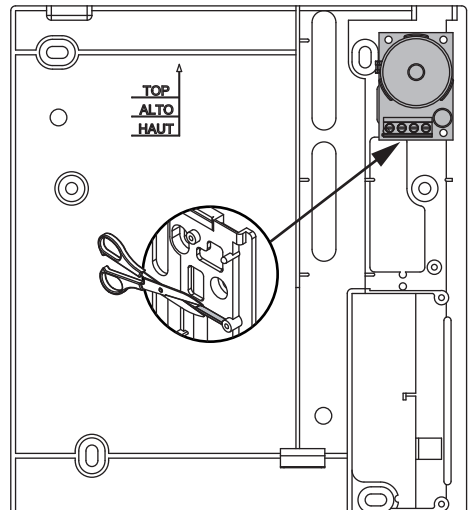

Artico Arco

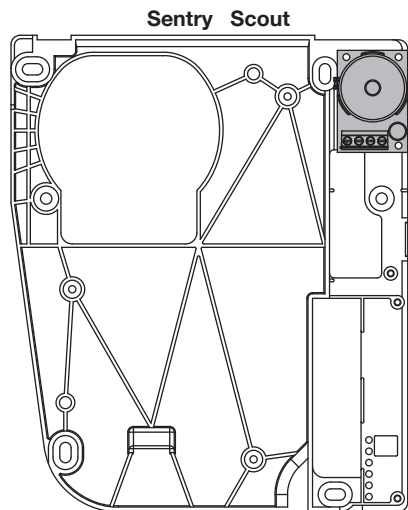
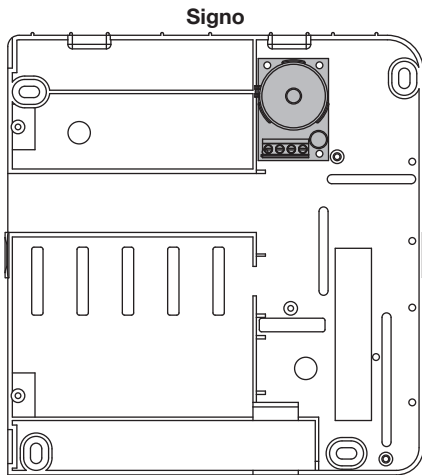



 Wird den Summer mit Relaiseinrichtungen BN 788/51 und BN 788/58 verwendet, muss der 47 Ohm Widerstand eingesetzt werden, indem man den Jumper verstellt.

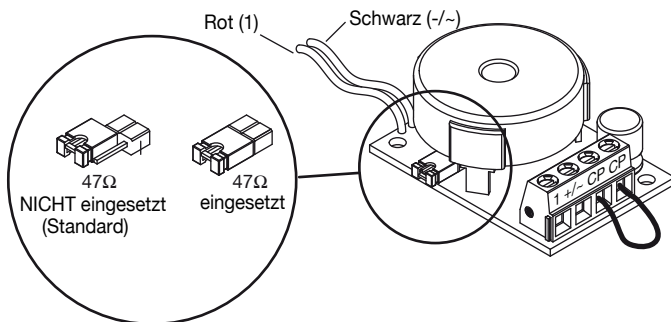

AUSWECHSELN VON VORIGEN MODELLEN

Beschreibung	BN 9854/56	BN 1131/7	BN 9854/52	BN 9854/53
Stromversorgung	+/~	RZ	+/~	CH
	-/~ (Schwarzer Draht)	Schwarzer Draht	-/~	
Etagenruf	CP			CP+
	CP			CP-
Widerstand Verringerung des Sprechkreises	1	1		
	1 (Roter Draht)	Roter Draht		

NOTE LEGATE AGLI SCHEMI
NOTES ON DIAGRAMS
REMARQUES CONCERNANT LES SCHÉMAS
NOTAS REFERIDAS A LOS ESQUEMAS
HINWEISE IN VERBINDUNG MIT DEN PLÄNEN

C4.003 Equivalenza morsetti

- T1 (Sch.1132/1) = A (Sch.1131/1)
- T2 (Sch.1132/1) = B (Sch.1131/1)
- T3 (Sch.1132/1) = C (Sch.1131/1)
- T4 (Sch.1132/1) = D (Sch.1131/1)

Terminal pins meaning

- T1 (Ref.1132/1) = A (Ref.1131/1)
- T2 (Ref.1132/1) = B (Ref.1131/1)
- T3 (Ref.1132/1) = C (Ref.1131/1)
- T4 (Ref.1132/1) = D (Ref.1131/1)

Correspondances bornes

- T1 (Réf.1132/1) = A (Réf.1131/1)
- T2 (Réf.1132/1) = B (Réf.1131/1)
- T3 (Réf.1132/1) = C (Réf.1131/1)
- T4 (Réf.1132/1) = D (Réf.1131/1)

Equivalencia bornes

- T1 (Ref.1132/1) = A (Ref.1131/1)
- T2 (Ref.1132/1) = B (Ref.1131/1)
- T3 (Ref.1132/1) = C (Ref.1131/1)
- T4 (Ref.1132/1) = D (Ref.1131/1)

Entsprechungen der Klemmen

- T1 (BN1132/1) = A (BN1131/1)
- T2 (BN1132/1) = B (BN1131/1)
- T3 (BN1132/1) = C (BN1131/1)
- T4 (BN1132/1) = D (BN1131/1)

C4.033 Sul buzzer inserire la resistenza da 47 Ohm spostando il jumper.

Move the jumper and insert the 47 Ohm resistor on the buzzer.

Sur le ronfleur, insérer la résistance de 47 Ohm en déplaçant le pontet.

En el zumbador introducir la resistencia de 47 Ohm moviendo el jumper.

Auf dem Summer den 47 Ohm Widerstand einsetzen und dabei den Jumper verstellen.

VD.007 Tasto di chiamata al piano. Distanza massima 10 m con cavo di sezione 1 mm².

Floor call button. Maximum distance 10m with 1 mm² cable.

Touche de l'appel à l'étage. Distance maximale 10 m avec câble de section 1 mm².

Tecla de llamada al piso. Distancia máxima 10 m con cable de sección 1 mm².

Etagenruf-Taste. Max. Abstand 10 m bei Kabel mit 1 mm² Querschnitt.

VX.014 Eventuale interruttore crepuscolare o similare per accensione luce.

Optional dusk/dawn switch or similar, for turning the light on.

Interrupteur crépusculaire optionnel ou similaire pour allumage lumière.

Eventual interruptor crepuscular o similar para activación luz.

Eventueller Dämmerungsschalter oder ähnliches Gerät zum Einschalten der Beleuchtung.

VX.021 Sul/i dispositivo/i tagliare i ponticelli: 6-10.

On the device/s cut the jumpers 6-10.

Sur le/s dispositif/s couper les pontets: 6-10.

En el/los dispositivo/s cortar los puentes: 6-10.

An dem/den Gerät/en die Brücken 6-10 durchtrennen.

Collegamento di 2 citofoni ad un portiere elettrico (P.E.). Chiamate singole dal P.E. Servizio intercomunicante tra i citofoni. Chiamate esterna su buzzer.

Connection of 2 door phones to an entrance panel (P.E.). Single calls from P.E. Intercom function among door phones. External call on buzzer.

Connexion de 2 interphones à un portier électrique (P.E.). Appels uniques depuis le P.E.. Service intercom parmi les interphones. Appel externe avec ronfleur.

Conexión de 2 interfonos con un portero eléctrico (P.E.). Llamadas singulares desde el P.E. Servicio intercomunicante entre los interfonos. Llamadas externas sobre zumbador.

Anschluss von 2 Haustelefonen an eine Türstation (P.E.). Einzelne Rufe von P.E aus.

Interkommunizierender Dienst unter den Haustelefonen. Externe Anrufe über Summer.

SC101-0729F

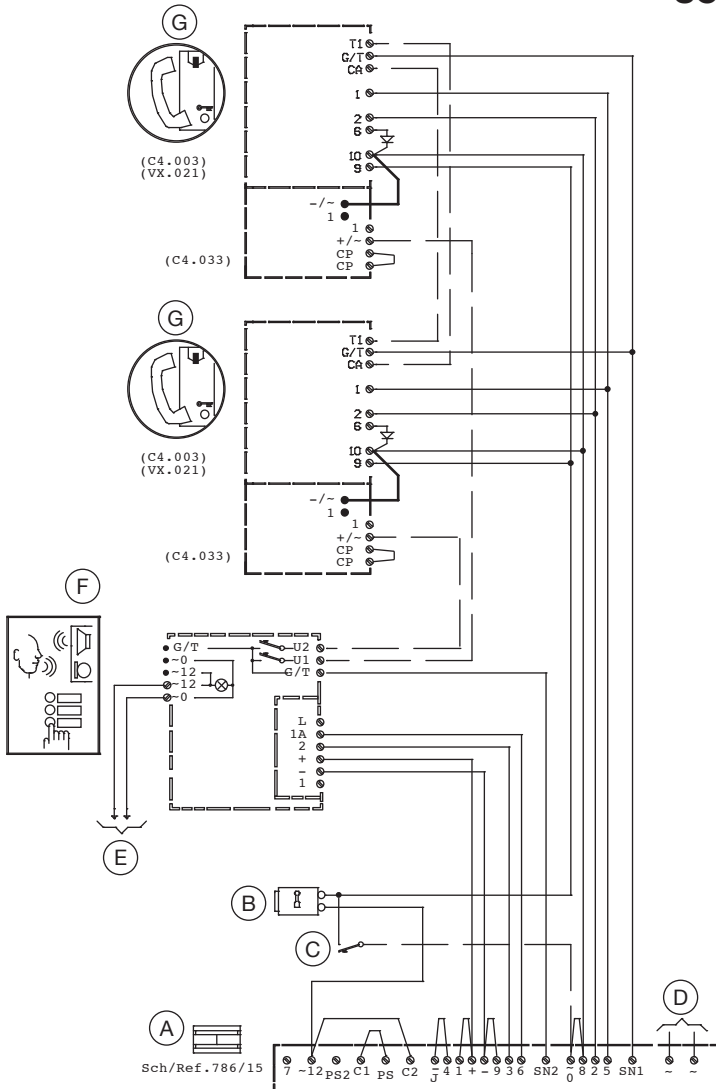

Collegamento di citofoni ad un portiere elettrico (P.E.). Servizio di chiamata al piano con alimentazione in continua.

Connection of door phones to an entrance panel (P.E.). Floor call function with direct current power supply.

Connexion d'interphones à un portier électrique (P.E.). Service d'appel à l'étage avec alimentation en courant continu.

Conexión de interfonos con un portero eléctrico (P.E.). Servicio de llamada al piso con alimentación en continua.

Anschluss von Haustelefonen an eine Türstation (P.E.). Etagenruf-Dienst mit Gleichspannungsversorgung.

SC101-1070F

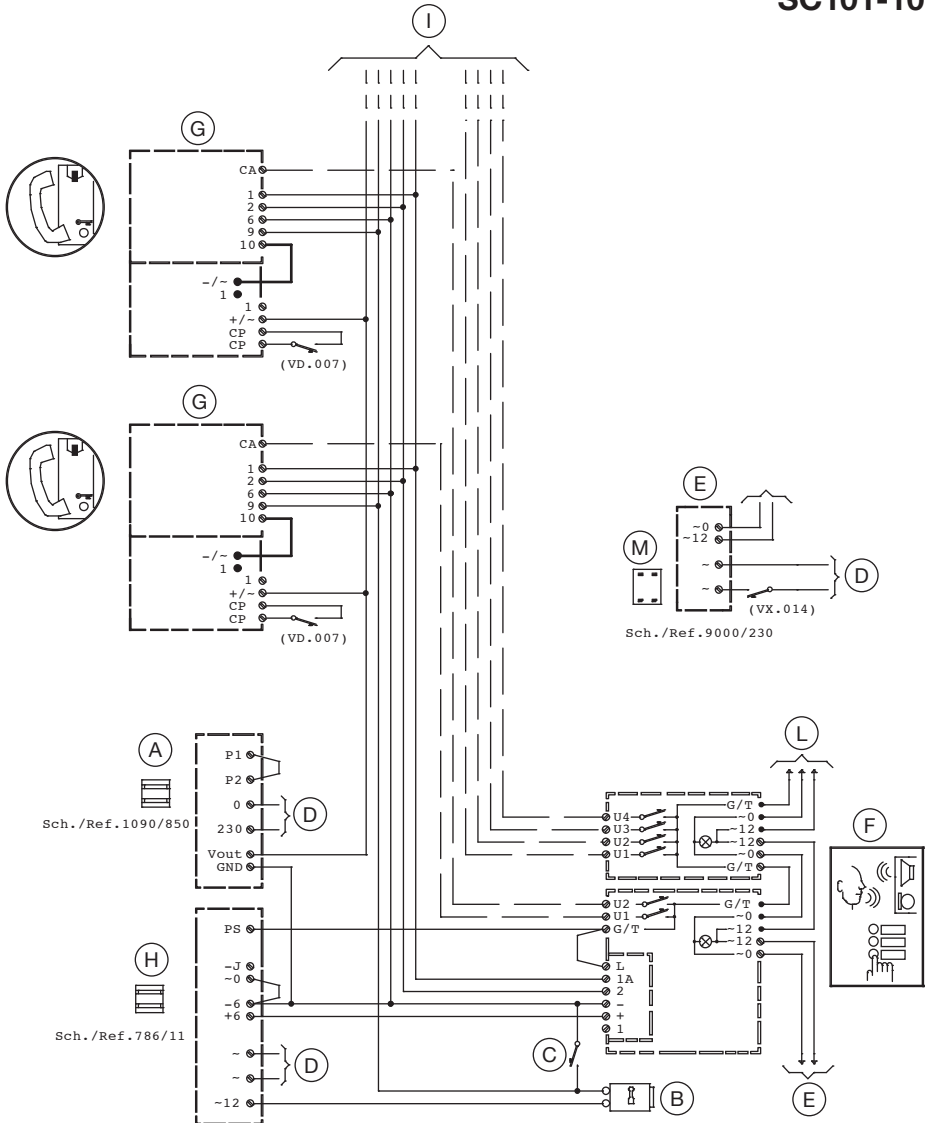

Collegamento di citofoni ad un impianto tradizionale.
Connection of door phones to a traditional system.
Connexion d'interphones à un système traditionnel.
Conexión de interfonos en un sistema tradicional.
Anschluss von Haustelefonen an eine traditionelle Anlage.

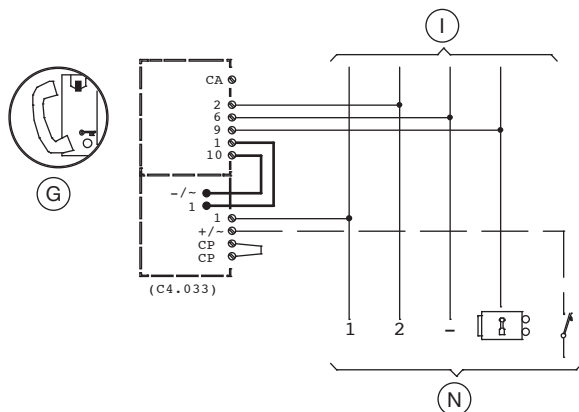

SC101-1463A

LEGENDA / KEY / LEGENDE / LEYENDA / KURZZEICHEN

- | | |
|---|--|
| <p>A - Alimentatore
 <i>Power supply</i>
 Alimentation
 <i>Alimentador</i>
 Netzteil</p> | <p>G - Citofono
 <i>Door phone</i>
 Interphone
 <i>Interfono</i>
 Sprechanlage</p> |
| <p>B - Serratura elettrica
 <i>Electric lock</i>
 Serrure électrique
 <i>Cerradura eléctrica</i>
 Elektrisches Schloß</p> | <p>H - Alimentatore citofonico
 <i>Door phone power supply</i>
 Alimentation poste
 <i>Alimentador para porteros</i>
 Haussprech-netzgerät</p> |
| <p>C - Azionamento apriporta
 <i>Door lock release activation</i>
 Activation ouvre-porte
 <i>Accionamiento apertura puerta</i>
 Aktivierung des Türöffner</p> | <p>I - Ai citofoni successivi
 <i>To the next door phones</i>
 Aux interphones suivants
 <i>Hacia los interfonos siguientes</i>
 An die nachfolgenden Haustelefonen</p> |
| <p>D - Rete ~
 <i>Mains ~</i>
 Secteur ~
 <i>Red ~</i>
 Netz ~</p> | <p>L - Ai moduli successivi
 <i>To next modules</i>
 Vers les modules suivants
 <i>A los siguientes módulos</i>
 An die nachfolgenden Module</p> |
| <p>E - Illuminazione cartellini
 <i>Name tag lighting</i>
 Eclairage des étiquettes
 <i>Iluminación de tarjeteros</i>
 Namensschildbeleuchtung</p> | <p>M - Trasformatore
 <i>Transformer</i>
 Transformateur
 <i>Transformador</i>
 Transformator</p> |
| <p>F - Portiere elettrico
 <i>Entrance panel</i>
 Portier électrique
 <i>Portero eléctrico</i>
 Türstation</p> | <p>N - Dalla colonna montante
 <i>From the riser column</i>
 De la colonne montante
 <i>Desde la columna principal</i>
 Von der Steigleitung</p> |

DS 9854-002B

URMET S.p.A.
10154 TORINO (ITALY)
VIA BOLOGNA 188/C
Telef. +39 011.24.00.000 (RIC. AUT.)
Fax +39 011.24.00.300 - 323

urmet

LBT 8639

Area tecnica
servizio clienti +39 011.23.39.810
<http://www.urmet.com>
e-mail: info@urmet.com

Fabbricato da Urmet Electronics Limited
(azienda del gruppo Urmet) - Made in P.R.C.
Manufactured by Urmet Electronics Limited
(an Urmet group company) - Made in P.R.C.