

F76S-1/2AA | Honeywell fiche



Réf F76S-1/2AA



Réf F76S-3/4AA



Réf F76S-1AA



Réf F76S-11/4AA



Réf F76S-11/2AA



Réf F76S-2AA

Voir les produits Honeywell : https://www.domomat.com/124_honeywell

Retrouvez tous les produits Honeywell
chez Domomat !

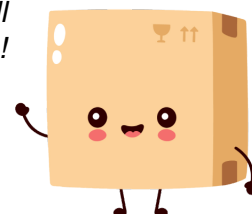

F76S

Reverse rinsing fine filter

Product specification sheet

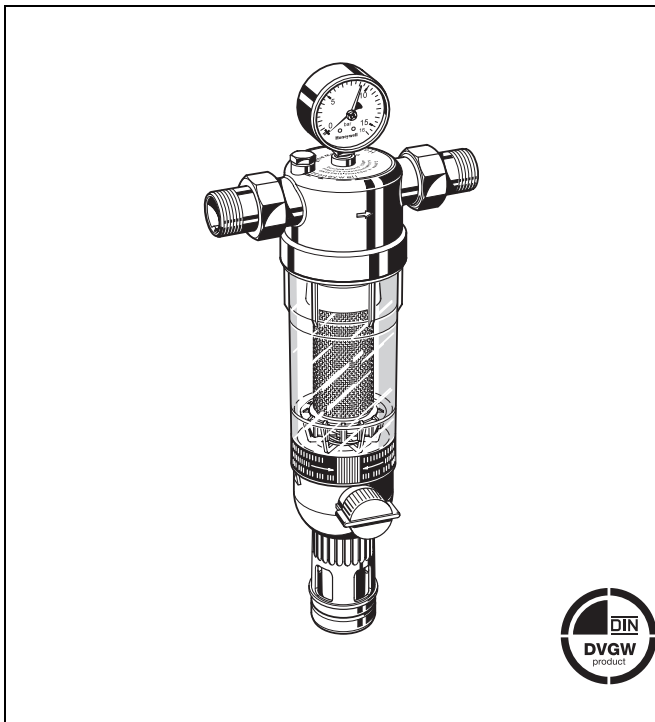

Construction

The fine filter comprises:

- Housing with pressure gauge
- Threaded male connections (versions AA and AAM)
- Fine filter in clear filter bowl (versions AA and EA)
- Filter in red-bronze filter bowl (version AAM)
- Fine filter in clear filter bowl
- Ball valve with drain connection
- Double wing wrench

Materials

- Dezincification resistant brass housing
- Brass threaded connections
- Stainless steel fine filter
- Red-bronze or shock-resistant, clear transparent synthetic material filter bowl
- NBR seals

Application

F76S reverse rinsing filters ensure a continuous supply of filtered water. The fine filter prevents the ingress of foreign bodies, for example rust particles, strands of hemp and grains of sand. The appliances correspond to the requirements of current DIN/DVGW specifications..

Special Features

- DIN/DVGW approved
- Double Spin Technology for connection sizes 1/2" to 1 1/4"
 - o Cartridge with external rotor enabling simultaneous cleaning in lower and upper filter areas
 - o Visual function check possible
- Filtered water supplied even during reverse rinsing
- Patented reverse rinsing system - fast and thorough cleaning of the filter with small amount of water
- Memory ring indicates when next manual reverse rinsing is due
- Automatic reverse rinsing actuator with bayonet connector can be retrofitted
- Large filter surface
- Shock resistant clear synthetic material filter bowl enables easy checking of filter contamination
- Filter and complete filter bowl are replaceable
- Also available without connections
- Standardised discharge connection
- Meets KTW recommendations for potable water

Range of Application

Medium Water

The filter is constructed for drinking water installations. In case of a process water application the filter has to be proven individually.

Technical Data

Installation position	Horizontal, with filter bowl downwards
Operating temperature	max. 40 °C with clear filter bowl max. 70 °C with red-bronze filter bowl
Operating pressure	min. 1.5 bar max. 16.0 bar with clear filter bowl max. 25.0 bar with red-bronze filter bowl
Connection size	1/2", 3/4", 1", 1 1/4", 1 1/2", 2"

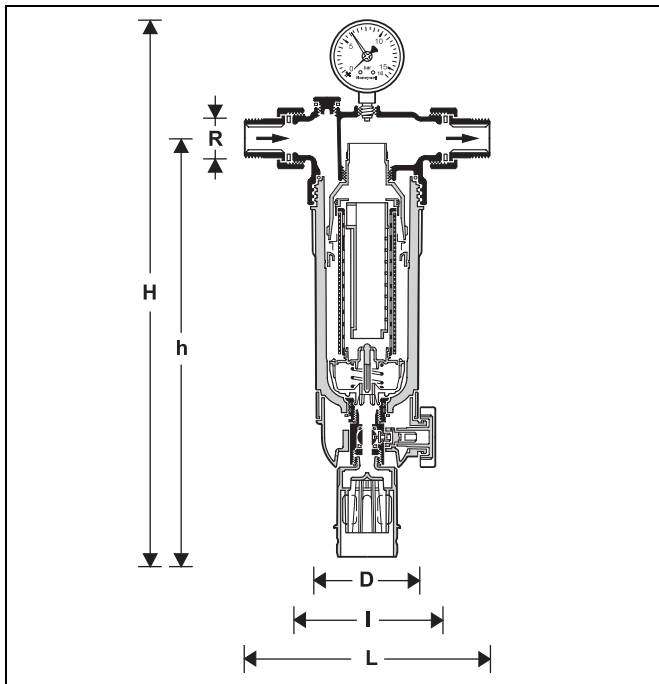

Method of Operation

The filter insert is divided into two parts. In the „filtering“ position, only the lower, larger section is rinsed through by water jets from outside to inside. The small upper section does not come in contact with unfiltered water. When the ball valve is opened for reverse rinsing, then the whole filter insert is pushed downwards until the water supply to the outer side of the main filter is stopped. Simultaneously, the water flow is opened to the upper part of the filter. The water needed for cleaning the filter passes through the upper filter section, then the rotating impeller and the main filter from inside to outside, i.e. the filter is reverse rinsed with filtered water. In that way the upper filter is also cleaned by jets from the impeller. The filter automatically switches back to the operating position when the ball valve is closed again.

Filters with Double Spin Technologie have turbine blades which circulate the water and thereby set the rotor on the upper filter into a rotational motion. The internal impeller rinses off particles that have adhered to the upper filter at the intersecting points with the rotor.

Options

- F76S-...AA = Threaded male connections, filter mesh size 100 µm
 - F76S-...AAM = Red-bronze filter bowl, threaded male connections, filter mesh size 100 µm
 - F76S-...EA = Without connections, filter mesh size 100 µm
- Connection size
Filters with other mesh widths available on request

Connection size	R	1/2"	3/4"	1"	1 1/4"	1 1/2"	2"
Nominal size diameter	DN	15	20	25	32	40	50
Weight	approx. kg	2.9	2.9	3.1	3.3	4.0	4.8
Dimensions	mm						
	L	170	178	209	222	246	267
	l	110	110	130	130	150	150
	H	449	449	453	453	532	532
	h	350	350	351	351	417	417
D		97	97	97	97	120	120
Flow value at Δp = 0.5 bar	m³/h	3.8	5.5	7.5	8.9	15.6	16.5
Kvs-value		4.8	7.2	9.8	10.7	21.0	22.0
DIN/DVGW Approval No.		NW-9301 AT 2308					
Double Spin Technologie		Yes	Yes	Yes	Yes	No	No

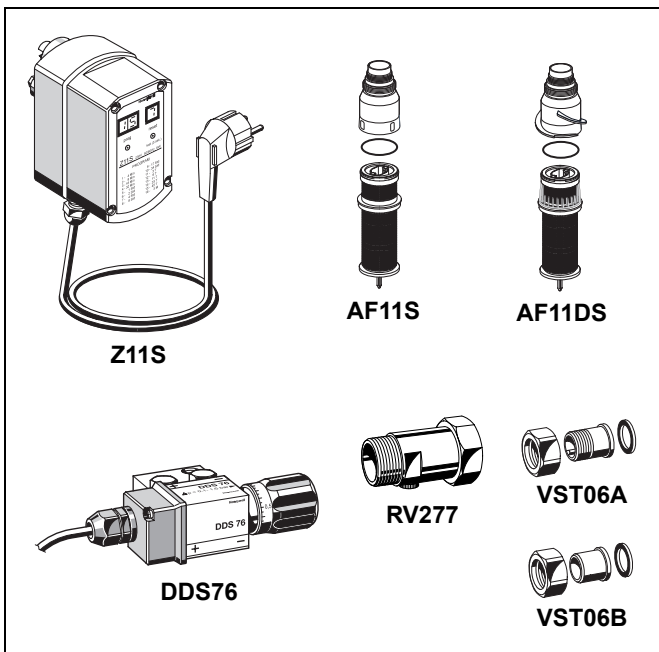

Accessories

- Z11S Automatic reverse rinsing actuator**
For automatic filter cleaning at presettable intervals
- RV277 Inlet check valve**
Available in sizes R1/2" - 2"
- VST06 Connection set**
Connection set
A = Threaded male connection;
B = Solder union connection
- DDS76 Differential pressure switch**
- AF11S Filter insert complete**
Available with filter meshes 20 µm, 50 µm, 100 µm, 200 µm, 300 µm, 500 µm
- AF11DS Filter insert complete**
Available with filter meshes 20 µm, 50 µm, 100 µm, 200 µm, 300 µm, 500 µm (for filters with Double Spin Technologie)

* The filter guide (either with double spin or without double spin feature) is included in the packaging of the replacement filter inserts (AF11DS and AF11S) only for the sizes 1/2" up to 1 1/4!"

Installation Example

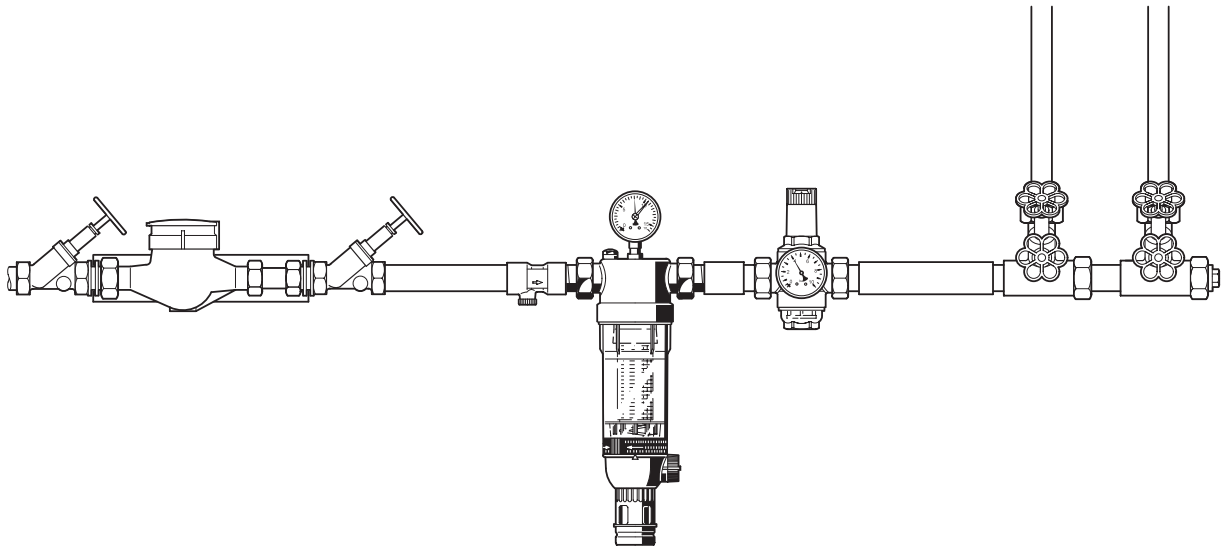

Installation Guidelines

- Install in horizontal pipework with filter bowl downwards
 - This position ensures optimum filter efficiency
- Install shutoff valves
 - Pressure gauge can be read off easily
 - Degree of contamination can be easily seen with clear filter bowl
 - Simplifies maintenance and inspection
- The installation location should be protected against frost
- Fit immediately after water meter
 - Corresponds to DIN 1988, Part 2

Typical Applications

Fine filters of this type are suitable for supplies to buildings of all types. They can also be used for commercial and industrial applications within the limits of their specifications.

Fine filters of this type are installed:

- Where there is existing metal or plastics pipework
- If the downstream system includes appliances which must be protected against dirt

Flow Diagram

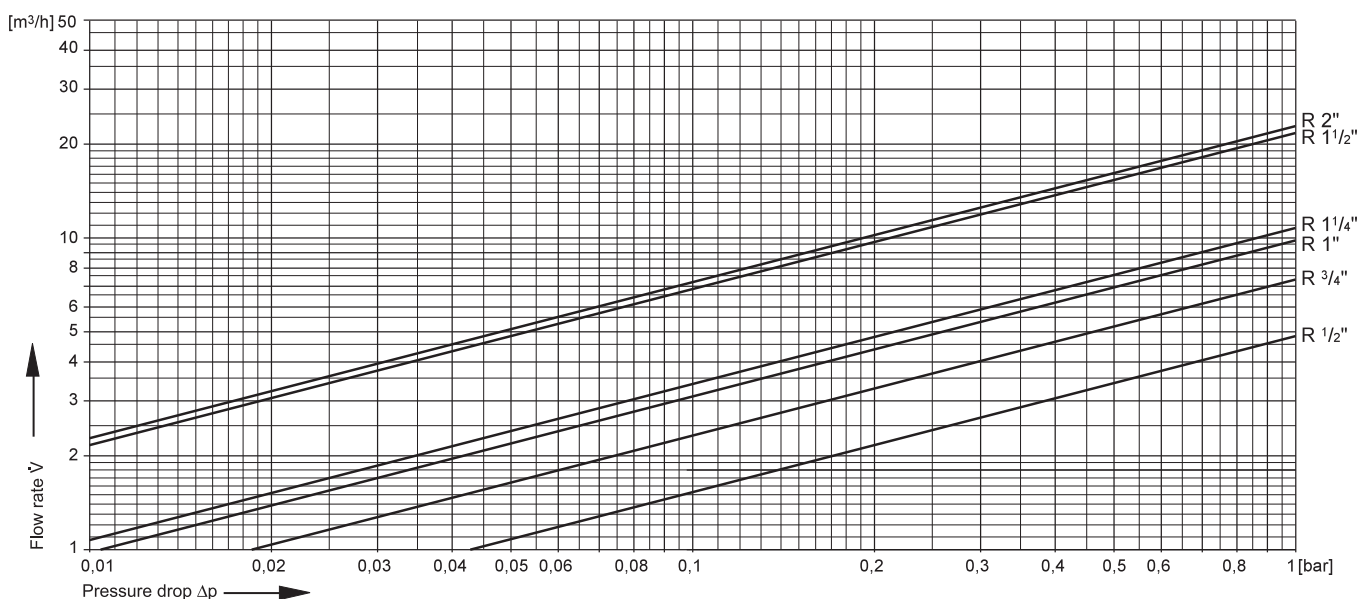

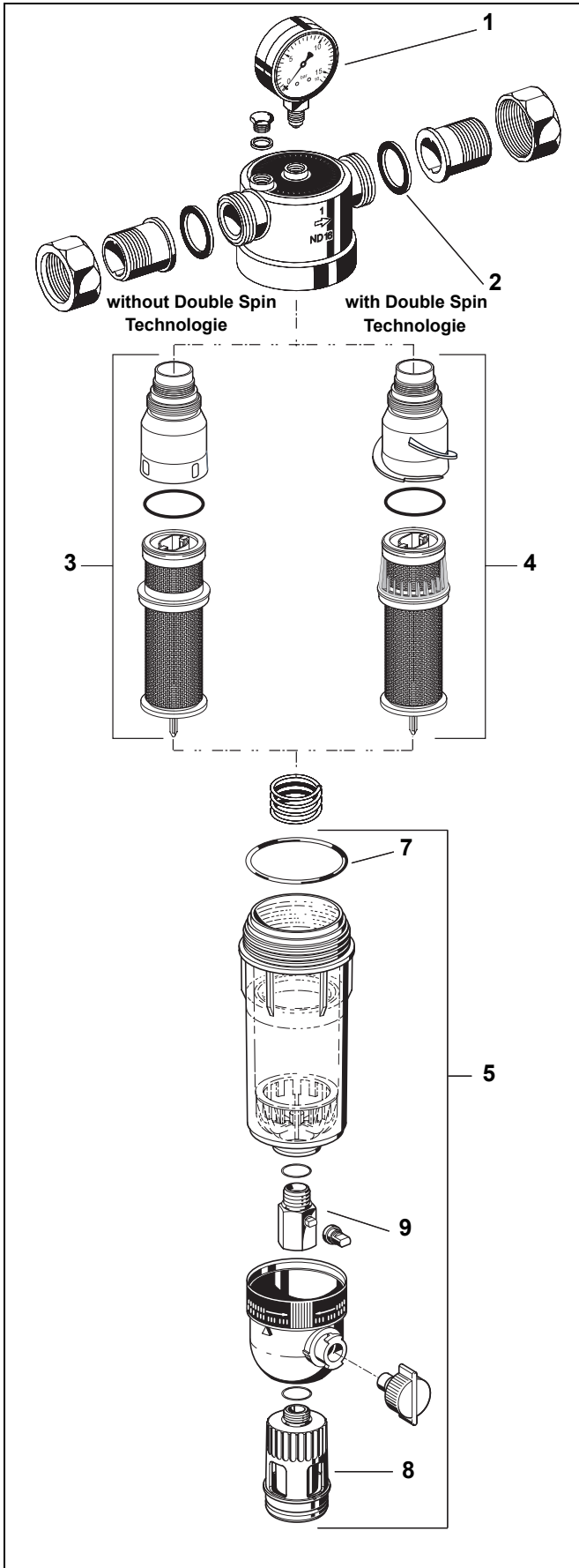

Spare Parts

F76S Fine Filters (from 2007 onwards)

No.	Description	Dimension	Part No.
1	Pressure gauge 0 - 16 bar		M76K-A16
2	Seal ring set (Pack of 10)	1/2" + 3/4" 1" 1 1/4" 1 1/2" 2"	0901444 0901445 0901446 0901447 0901448
3	Filter insert complete* Filter mesh 100 µm	1/2" - 3/4" 1" - 1 1/4" 1 1/2" - 2"	AF11S-1/2A AF11S-1A AF11S-11/2A
4	Filter insert complete* for filters with Double Spin Technologie, Filter mesh 100 µm	1/2" - 3/4" 1" - 1 1/4"	AF11DS-1/2A AF11DS-1A
5	Clear filter bowl	1/2" - 1 1/4" 1 1/2" - 2"	KF11S-1A KF11S-11/2A
6	Red-bronze filter bowl	1/2" - 1 1/4" 1 1/2" - 2"	FT09RS-1A FT09RS-11/2A
7	O-ring set (Pack of 10)	1/2" - 1 1/4" 1 1/2" - 2"	0900747 0900748
8	Drain connector	1/2" - 2"	AA76-1/2A
9	Ball valve complete	1/2" - 2"	KH11S-1A
10	Double ring wrench For removing the filter bowl (no fig.)	1/2" - 3/4" 1" - 1 1/4" 1 1/2" - 2"	ZR10K-3/4 ZR10K-1 ZR10K-11/2

* The filter guide (either with double spin or without double spin feature) is included in the packaging of the replacement filter inserts (AF11DS and AF11S) only for the sizes 1/2" up to 1 1/4"!

Automation and Control Solutions

Honeywell GmbH
 Hardhofweg
 D-74821 Mosbach
 Phone: (49) 6261 810
 Fax: (49) 6261 81309
<http://europe.hbc.honeywell.com>
www.honeywell.com

Manufactured for and on behalf of the
 Environmental and Combustion Controls Division
 of Honeywell Technologies Sàrl, Rolle, Z.A. La
 Pièce 16, Switzerland by its Authorised Repre-
 sentative Honeywell GmbH

EN0H-1110GE23 R0409
 Subject to change without notice
 © 2009 Honeywell GmbH

Honeywell