

Notice contact auxiliaire



Contact signal défaut inverseur Legrand - DX³ - 6A 240V~ - 0,5 module

Réf 406260 **64.67€^{TTC*}**

<https://www.domomat.com/63343-contact-signal-defaut-inverseur-legrand-dx-6a-240v-05-module-legrand-406260.html>



Contact auxiliaire inverseur (CA/SD) Legrand - DX³ - 6A 240V~ - 0,5 module

Réf 406262 **76.97€^{TTC*}**

<https://www.domomat.com/63352-contact-auxiliaire-inverseur-casd-legrand-dx-6a-240v-05-module-legrand-406262.html>

Retrouvez tous les produits de la catégorie
Contacts auxiliaires Legrand
chez Domomat !

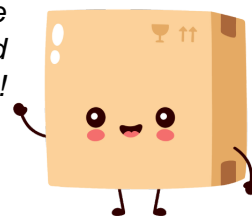

* : Prix sur le site Domomat.com au 17/04/2024. Le prix est susceptible d'être modifié.

4 062 50/52/56

4 062 58/60/62

4 062 64

4 062 66

4 062 76/78

4 062 80/82

4 062 84

4 062 85

4 062 86

4 062 87

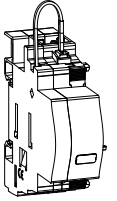
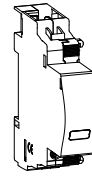
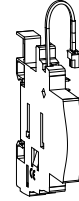
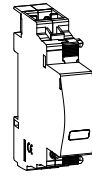
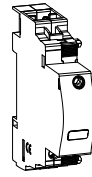
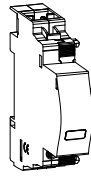
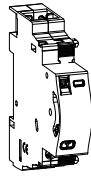
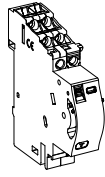
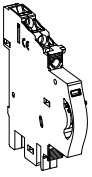

CA

4 062 50/58

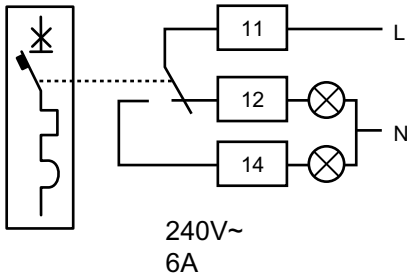
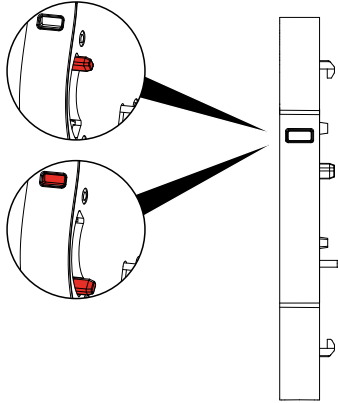

SD

4 062 52/60

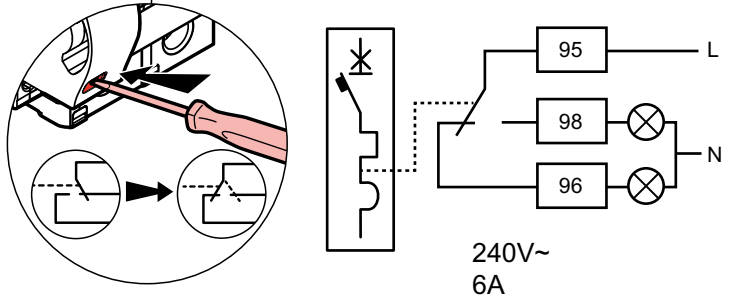
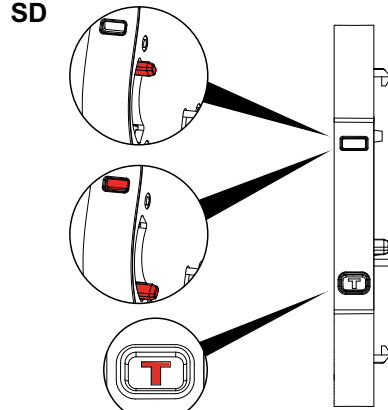

CA/SD

4 062 56/62

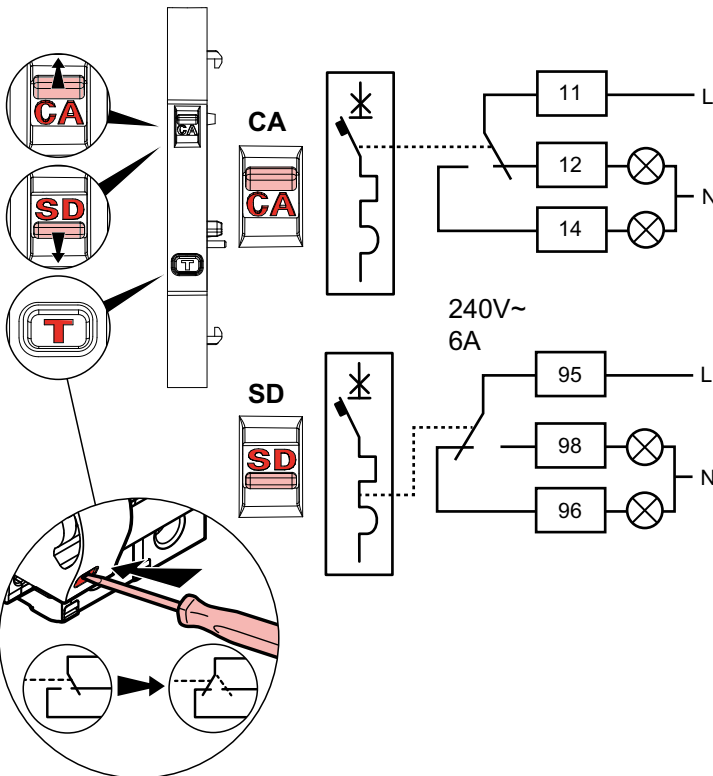

CA+SD
CA+CA

4 062 64/66

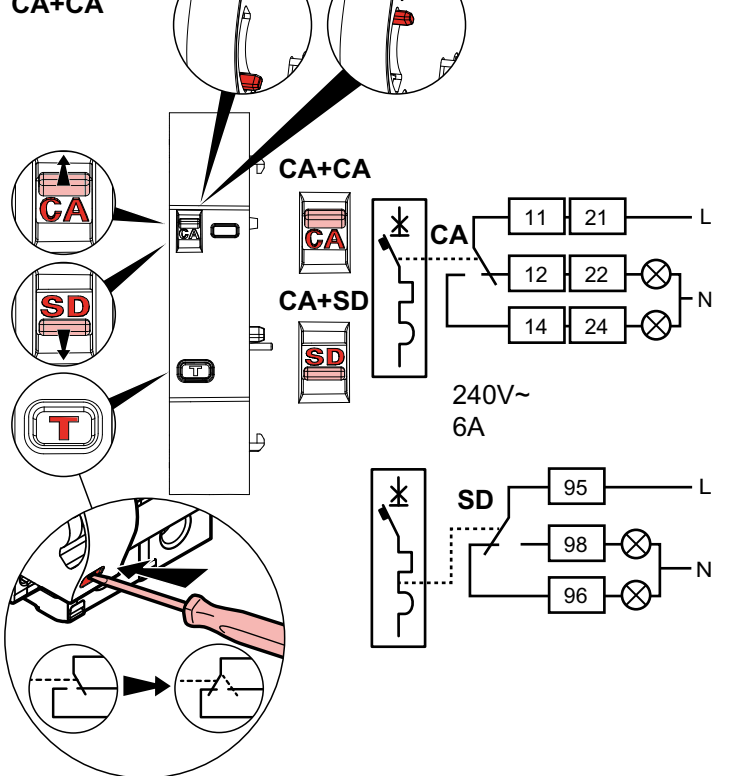

ET

4 062 76
4 062 78

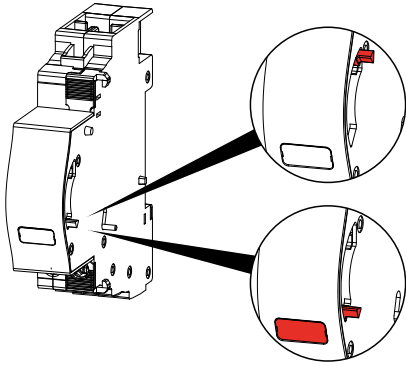
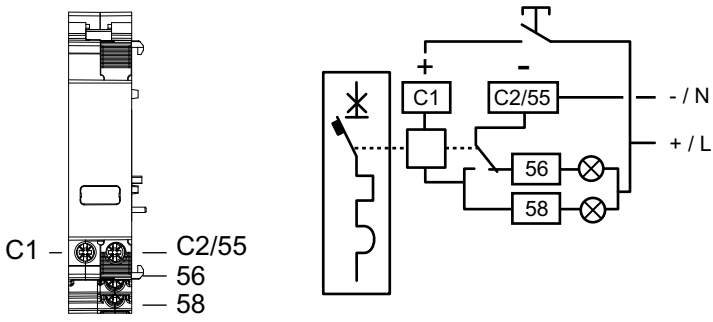

POP

4 062 86

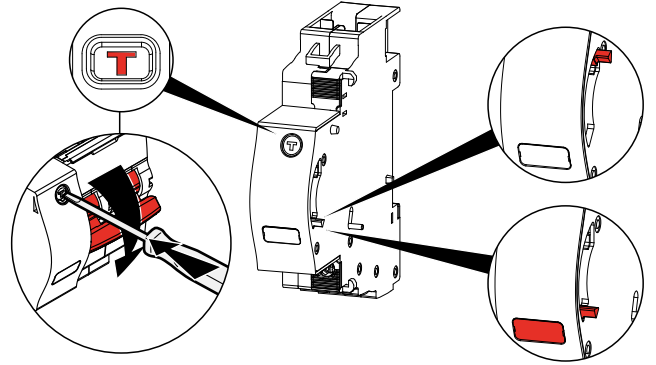
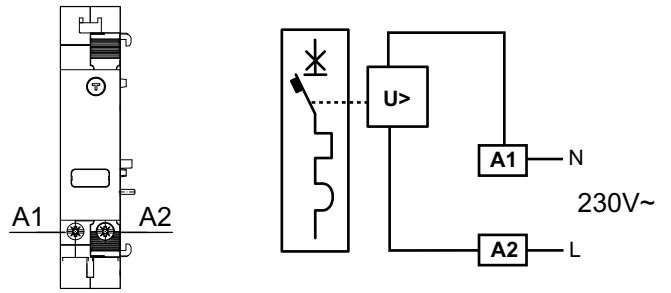

MT

4 062 80

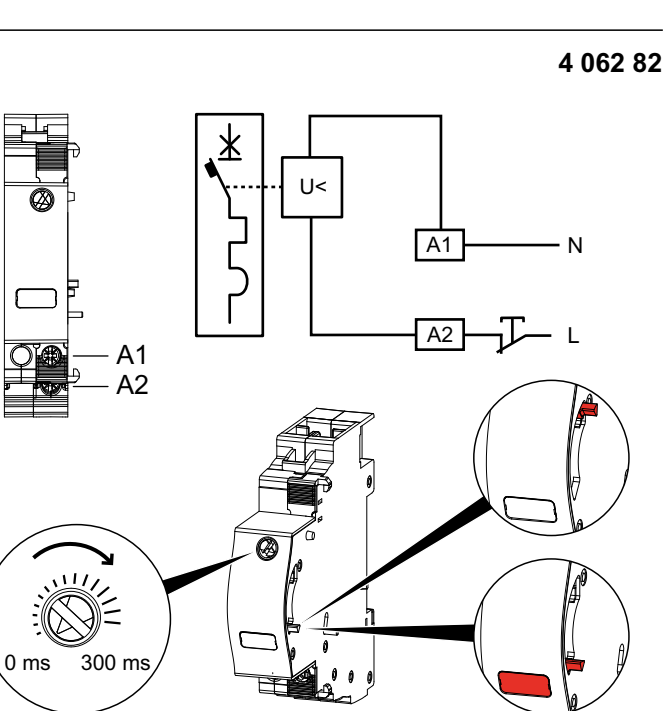
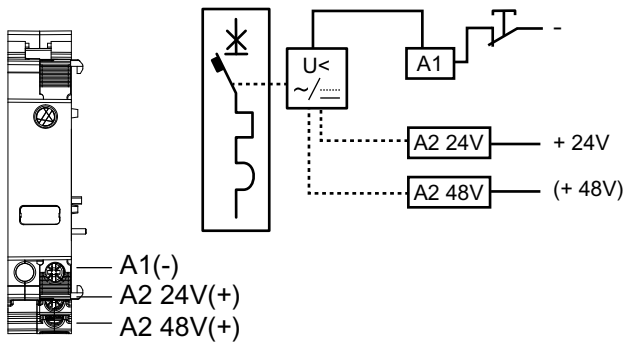

DA

4 062 84
4 062 85
4 062 87

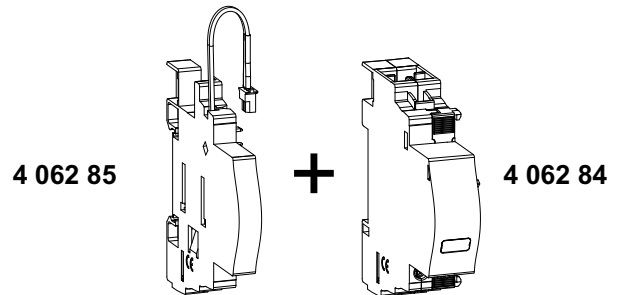
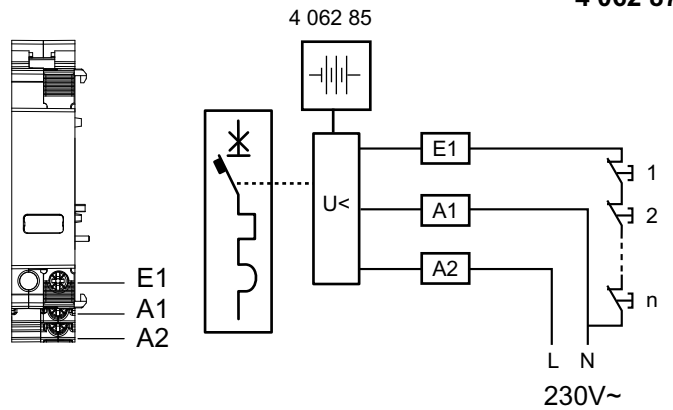

4 062 87

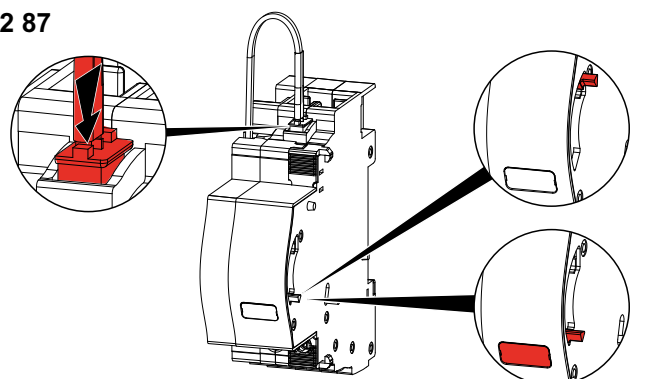

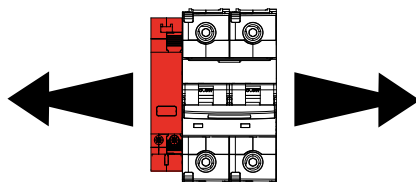
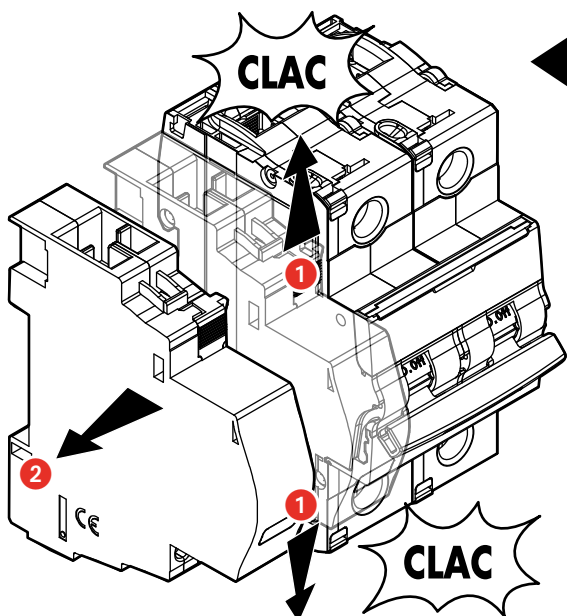
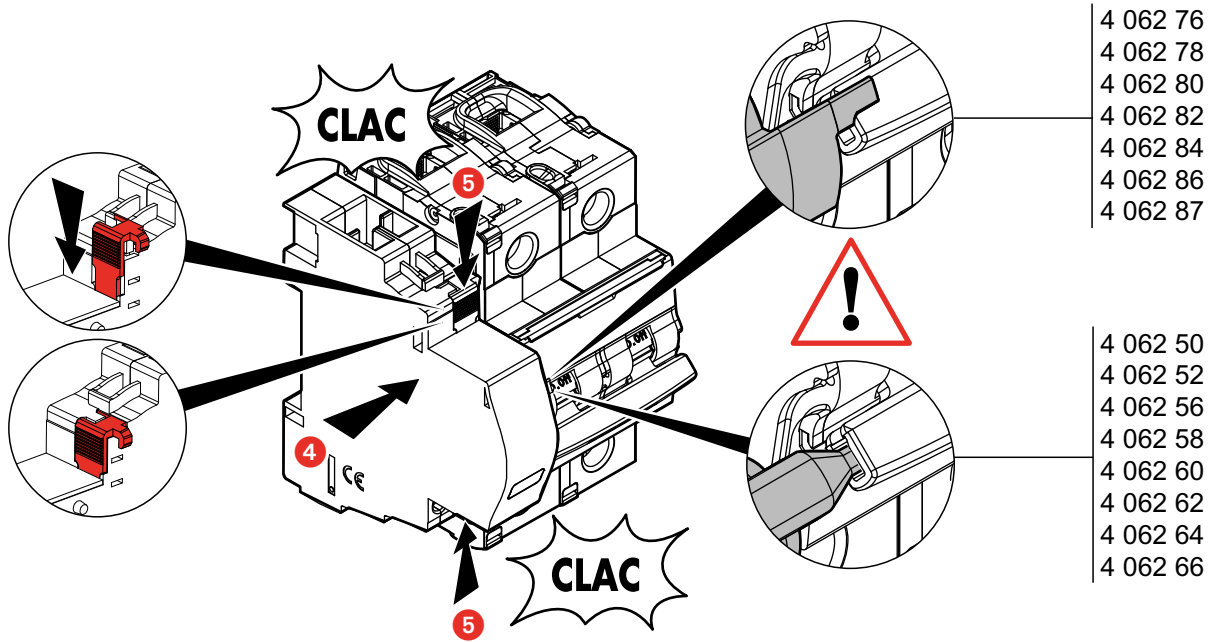
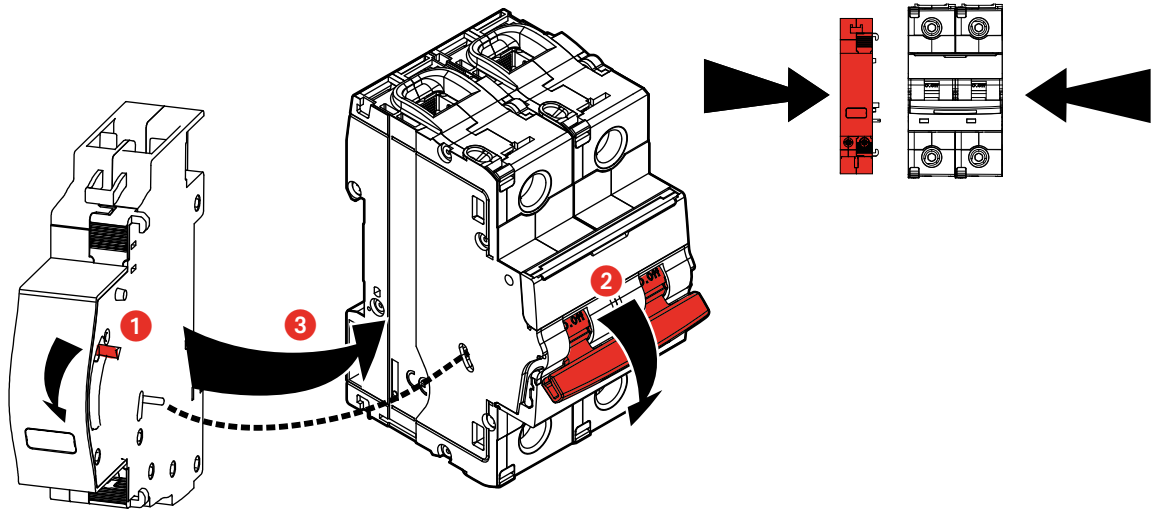

PZ 1



1Nm
MAX

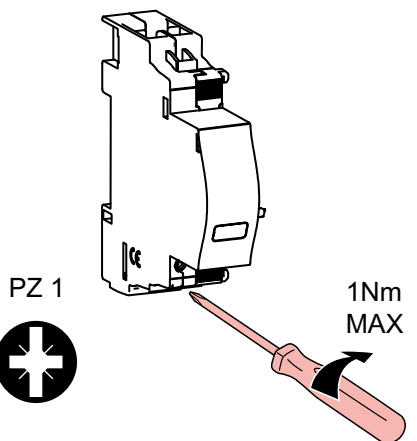

8 mm

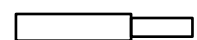
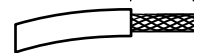

MAX
2 X 1,5 mm²

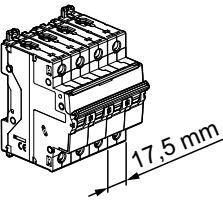
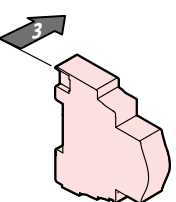
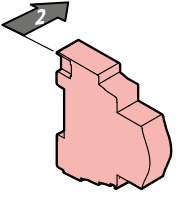
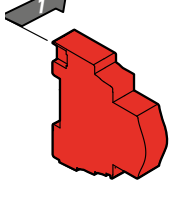
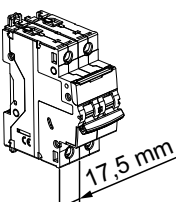
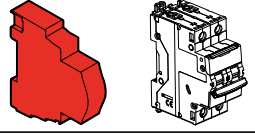
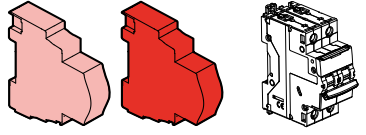
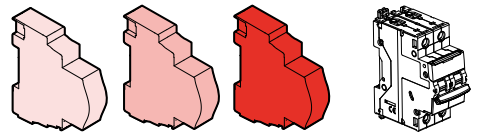
				
				4 062 .. 50 / 52 / 56 / 58 / 60 / 62 / 64 / 66 / 76 / 78 / 80 / 82 / 84 / 86 / 87 4 149 29
		4 062 .. 50 / 52 / 56 / 58 / 60 / 62 / 76 / 78 / 80 / 82 / 84 / 86 / 87 4 149 29	4 062 .. 50 / 52 / 56 / 58 / 60 / 62 4 149 29	
	4 062 .. 76 / 78 / 80 / 82 / 84 / 86 / 87	4 062 .. 50 / 52 / 56 / 58 / 60 / 62 4 149 29	4 062 .. 50 / 52 / 56 / 58 / 60 / 62 4 149 29	
		4 062 .. 50 / 52 / 56 / 58 / 60 / 62 / 64 / 66 / 76 / 78 / 80 / 82 / 84 / 86 / 87 4 149 29	4 062 .. 64 / 66	
		4 062 .. 50 / 52 / 56 / 58 / 60 / 62 4 149 29	4 062 .. 50 / 52 / 56 / 58 / 60 / 62 4 149 29	
		4 062 .. 50 / 52 / 56 / 58 / 60 / 62 / 64 / 66 4 149 29	4 062 .. 64 / 66	

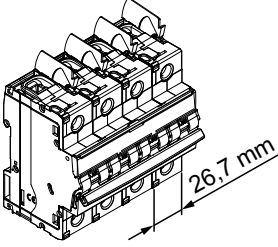
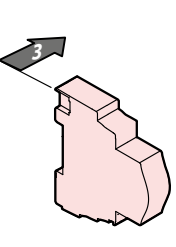
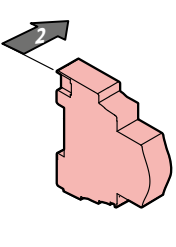
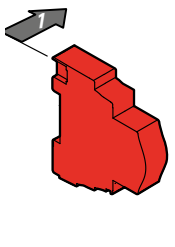
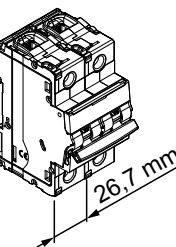
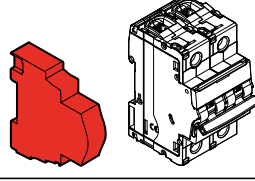
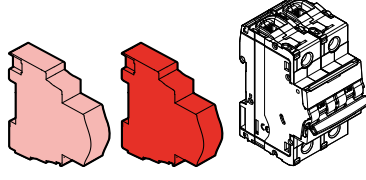
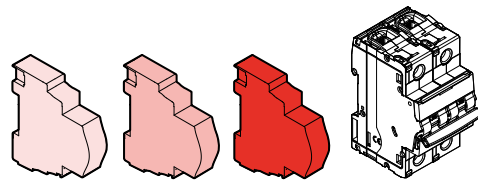
				
				4 062 .. 50 / 52 / 56 / 58 / 60 / 62 / 64 / 66 / 76 / 78 / 80 / 82 / 84 / 86 / 87 4 149 29
		4 062 .. 50 / 52 / 56 / 58 / 60 / 62 4 149 29	4 062 .. 50 / 52 / 56 / 58 / 60 / 62 4 149 29	
	4 062 .. 76 / 78 / 80 / 82 / 84 / 86 / 87	4 062 .. 50 / 52 / 56 / 58 / 60 / 62 / 64 / 66 / 76 / 78 / 80 / 82 / 84 / 86 / 87 4 149 29	4 062 .. 64 / 66	
		4 062 .. 50 / 52 / 56 / 58 / 60 / 62 4 149 29	4 062 .. 64 / 66	
		4 062 .. 50 / 52 / 56 / 58 / 60 / 62 / 64 / 66 4 149 29	4 062 .. 64 / 66	
		4 062 .. 50 / 52 / 56 / 58 / 60 / 62 4 149 29	4 062 .. 50 / 52 / 56 / 58 / 60 / 62 4 149 29	
		4 062 .. 50 / 52 / 56 / 58 / 60 / 62 / 64 / 66 / 76 / 78 / 80 / 82 / 84 / 86 / 87 4 149 29	4 062 .. 64 / 66	
		4 062 .. 50 / 52 / 56 / 58 / 60 / 62 4 149 29	4 062 .. 50 / 52 / 56 / 58 / 60 / 62 4 149 29	
		4 062 .. 50 / 52 / 56 / 58 / 60 / 62 / 64 / 66 4 149 29	4 062 .. 64 / 66	

<p>Ne pas respecter strictement les conditions d'installation et d'utilisation peut entraîner des risques de choc électrique ou d'incendie.</p> <p>Door de installatie- en gebruiksvoorwaarden niet strikt na te leven, kan er gevaar voor elektrische schokken of brand ontstaan.</p> <p>The instructions for installation and use must be strictly observed in order to avoid the risk of electric shock or fire.</p> <p>Bei Nichtbeachtung der Einbau- und Nutzungsvorschriften besteht Stromschlag- bzw. Brandgefahr.</p> <p>El no cumplimiento estricto de las instrucciones de instalación y uso puede implicar riesgos de choque eléctrico o incendio.</p> <p>Il non rispetto alla lettera delle condizioni d'installazione e di utilizzo può generare rischi di scariche elettriche o di incendio.</p> <p>Não respeitar estritamente as condições de instalação e de utilização poderá provocar riscos de choque eléctrico ou de incêndio.</p> <p>Η μη αυστηρή τήρηση των συνθηκών εγκατάστασης και χρήσης μπορεί να επιφέρει κινδύνους ηλεκτροπληξίας ή πυρκαγιάς.</p> <p>Несоблюдение правил монтажа и эксплуатации может повлечь за собой риск поражения электрическим током или возникновения пожара.</p> <p>Niezastosowanie się ściśle do warunków instalacji i użytkowania może grozić porażeniem prądem lub pożarem.</p> <p>Yerleşirme ve kullanım koşullarına uyulmaması elektrik çarpması veya yangın risklerine yol açabilir.</p> <p>A beszerelési és használati feltételek szigorú betartásának elmulasztása áramütés vagy tűz kockázatával jár.</p> <p>Jos et noudata tarkasti asennus- ja käyttöohjeita, voit aiheuttaa sähköiskun vaaran tai tulipalon.</p>	<p>(FR) (LU) (BE) (CH)</p> <p>(NL) (BE)</p> <p>(GB) (IE)</p> <p>(DE) (AT) (LI) (CH)</p> <p>(ES)</p> <p>(IT) (CH)</p> <p>(PT)</p> <p>(GR) (CY)</p> <p>(RU)</p> <p>(PL)</p> <p>(TR) (CY)</p> <p>(HU)</p> <p>(FI)</p>	<p>Om installationsvillkoren inte uppfylls strikt, föreligger risk för elchocker eller brand.</p> <p>Nedodržení stanovených podmínek instalace a používání může vést k rizikům zasažení elektrickým proudem nebo požáru.</p> <p>V prípade nedodržania presných podmienok týkajúcich sa inštalácie a používania hrozí riziko úrazu elektrickým prúdom alebo vzniku požiaru.</p> <p>Neupoštjevanje vseh pogojev instalacije in uporabe lahko povzroči nevarnost električnega udara ali požara.</p> <p>Hvis installations- og brugsbetingelserne ikke strengt overholdes, kan det medføre risiko for elektrisk stød eller brand.</p> <p>Kui paigaldamis- ja kasutustingimusi ei järgita rangelt, võib see kaasa tuua elektrišoki või tulekahjuohtu.</p> <p>Precizni neievērojot uzstādīšanas un lietošanas noteikumus, pieaug elektriskās strāvas trieciena vai ugunsgrēka iespējamība.</p> <p>Tiksliai nesilaikant instalavimo ir naudojimo sąlygų gali kilti trumpojo elektros jungimo arba gaisro pavojus.</p> <p>Manglene overhold av installasjons- og brugsbetingelsene kan føre til elektrisk støt eller brann.</p> <p>Ef skilyrdum um uppsætningu og notkun er ekki vandlega fylgt kann slíkt að valda hættu á raflosti eða eldsvoða.</p> <p>Nerespectarea strictă a condițiilor de instalare și utilizare poate genera riscuri de șocuri electrice sau incendii.</p> <p>Неспазването стриктно на указанията за съглобяване и използване може да доведе до риск от токов удар или пожар.</p>	<p>(SE)</p> <p>(CZ)</p> <p>(SK)</p> <p>(SI)</p> <p>(DK)</p> <p>(EE)</p> <p>(LV)</p> <p>(LT)</p> <p>(NO)</p> <p>(IS)</p> <p>(RO)</p> <p>(BG)</p>
-----------------------------------------------------------------------------------------------------------------------------------------------------------------------------------------------------------------------------------------------------------------------------------------------------------------------------------------------------------------------------------------------------------------------------------------------------------------------------------------------------------------------------------------------------------------------------------------------------------------------------------------------------------------------------------------------------------------------------------------------------------------------------------------------------------------------------------------------------------------------------------------------------------------------------------------------------------------------------------------------------------------------------------------------------------------------------------------------------------------------------------------------------------------------------------------------------------------------------------------------------------------------------------------------------------------------------------------------------------------------------------------------------------------------------------------------------------------------------------------------------------------------------------------------------------------------------------------------------------------------------------------------------------------------------------	--------------------------------------------------------------------------------------------------------------------------------------------------------------------------------------------------------------------	---------------------------------------------------------------------------------------------------------------------------------------------------------------------------------------------------------------------------------------------------------------------------------------------------------------------------------------------------------------------------------------------------------------------------------------------------------------------------------------------------------------------------------------------------------------------------------------------------------------------------------------------------------------------------------------------------------------------------------------------------------------------------------------------------------------------------------------------------------------------------------------------------------------------------------------------------------------------------------------------------------------------------------------------------------------------------------------------------------------------------------------------------------------------------------------------------------------------------------------------------------------------------------------------------------------------------------------------------------------------------------------------------------------------------------------------------------------------------------------------------	-------------------------------------------------------------------------------------------------------------------------------------------------